

1) Product main performance/产品主要性能指标:

Operating Temperature/工作温度: -55°C~200°C  
 Humidity(max)/最大潮湿: <=95% [at 60 deg C / 140 F]  
 Shielding /屏蔽性能: 75dB(10MHz) 40dB(1GHz)  
 Salt Spray Corrosion/盐雾: 96hr  
 P op (max)/最大环境压力: 60 bar (870 psi)

Mechanical data/机械特性:

Vibration/振动: 15g[10Hz~2000Hz]  
 Shock Resistance/冲击: 100g[6ms]  
 Endurance (Shell)/机械寿命: 5000次  
 Cable/配接电缆: Ø4.4mm-Ø5.3mm

2. 电气性能

Insert Configuration/针芯配置: 1T.304 4Low Voltage  
 Pin Size/接触件直径: Ø0.9mm  
 Contact resistance接触电阻: ≤9mΩ  
 Insulation resistance/绝缘电阻: 5000MΩ (测试电压500V(DC))  
 Withstand voltage/耐电压: 875V(AC)  
 Rated working current额定工作电流: 10.0A

Other Specification/其它规格:

Contact PIN/接触体: Gold plated Tin bronze/锡青铜镀金  
 Housing Material/外壳材质: Chrome plated brass/铜镀珍珠铬  
 Other metal spare parts/其余金属件: Nickel plated brass/铜镀镍  
 Insulator material/绝缘材料: PPS  
 IP Rating/防护等级: IP68(插合状态)

\*ALL MATERIALS ARE RoHS COMPLIANT/所有材料均符合RoHS要求.

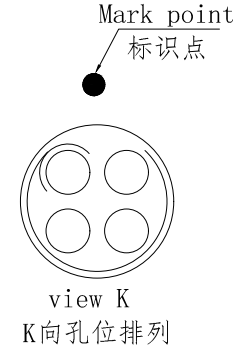
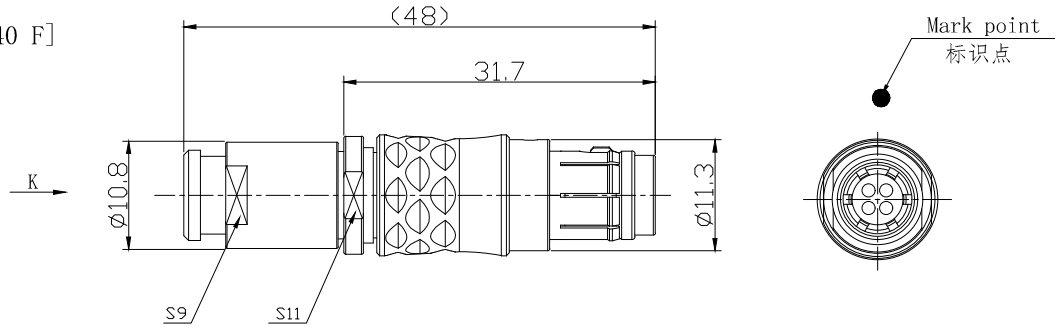

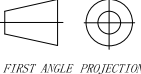
DRAWN BY: 绘图: Z01 2024.6.20		 美易连 MEIYILIAN 美易连	美易连电子科技(深圳)有限公司 Meiyilian electronic technology(shenzhen)Co.Ltd.		
CHECKED BY: 审核: Z01 2024.6.20			UNIT: mm	名称	1T-TG直式插头
APPROVED BY: 核准: PD05 2024.6.20			比例 SCALE: 1:1	PART NAME	1T-TG Straight plug
GENERAL TOLERANCE (UNLESS SPECIFIED)		 FIRST ANGLE PROJECTION	SIZE: A4	型号	
≤10 ±0.1 <10~≤20 ±0.15 <20~≤50 ±0.3 Angle ±1°			REV/版本	A1	SHEET: 1 OF 1
				PART NAME	TGG. 1T. 304. CLAC55Z