

1) Product main performance/产品主要性能指标:

Operating Temperature/工作温度 : -55°C~200°C  
 Humidity(max)/最大潮湿 : <=95% [at 60 deg C / 140 F]  
 Shielding /屏蔽性能 : 75dB(10MHz) 40dB(1GHz)  
 Salt Spray Corrosion/盐雾 : 96hr  
 P op (max)/最大环境压力 : 60 bar (870 psi)

Mechanical data/机械特性:

Vibration/振动 : 15g[10Hz~2000Hz]  
 Shock Resistance/冲击 : 100g[6ms]  
 Endurance (Shell)/机械寿命 : 5000次  
 Cable/配接电缆:  $\phi 3.1\text{mm}-\phi 4.0\text{mm}$

2. 电气性能

Insert Configuration/针芯配置: 0T.303 3Low Voltage  
 Pin Size/接触件直径:  $\phi 0.9\text{mm}$   
 Contact resistance接触电阻:  $\leq 9\text{m}\Omega$   
 Insulation resistance/绝缘电阻:  $5000\text{M}\Omega$  (测试电压500V(DC))  
 Withstand voltage/耐电压: 875V(AC)  
 Rated working current 额定工作电流: 8.0A

Other Specification/其它规格:

Contact PIN/接触体: Gold plated Tin bronze/锡青铜镀金  
 Housing Material/外壳材质: Chrome plated brass/铜镀珍珠铬  
 Other metal spare parts/其余金属件: Nickel plated brass/铜镀镍  
 Insulator material/绝缘材料: PPS  
 IP Rating/防护等级: IP68(插合状态)

\*ALL MATERIALS ARE RoHS COMPLIANT/所有材料均符合RoHS要求.

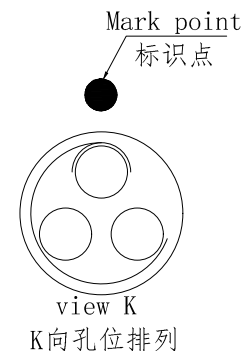
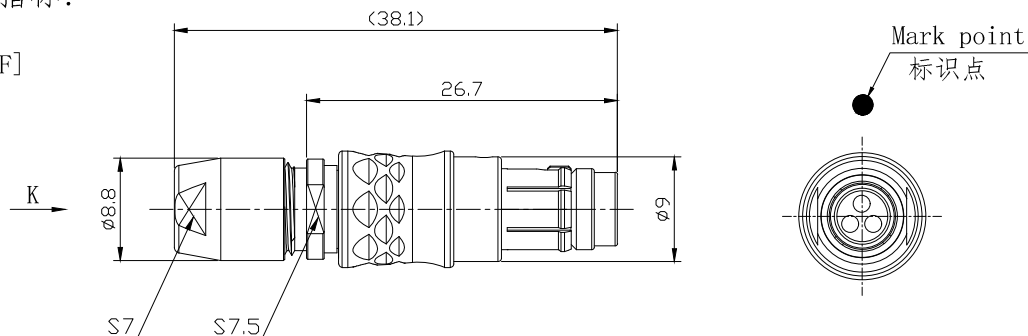

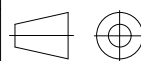
DRAWN BY: 绘图: Z01 2024. 6. 20 CHECKED BY: 审核: Z01 2024. 6. 20 APPROVED BY: 核准: PD05 2024. 6. 20		 美易连电子科技 (深圳) 有限公司 Meiyilian electronic technology (shenzhen) Co. Ltd.		
GENERAL TOLERANCE (UNLESS SPECIFIED) $\leq 10 \pm 0.1$ $< 10 \sim \leq 20 \pm 0.15$ $< 20 \sim \leq 50 \pm 0.3$ Angle $\pm 1^\circ$		 FIRST ANGLE PROJECTION	单位 UNIT: mm 名称 PART NAME 比例 SCALE: 1: 1 型号 TYPE	OT-TG直式插头 OT-TG Straight plug TGG. 0T. 303. CLAC42
REV/版本	A1	SHEET: 1 OF 1		