

1) Product main performance/产品主要性能指标:

Operating Temperature/工作温度: $-55^{\circ}\text{C} \sim 200^{\circ}\text{C}$

Humidity(max)/最大潮湿: $\leq 95\%$ [at 60 deg C / 140 F]

Shielding /屏蔽性能: 75dB(10MHz) 40dB(1GHz)

Salt Spray Corrosion/盐雾: 96hr

P op (max)/最大环境压力: 60 bar (870 psi)

Mechanical data/机械特性:

Vibration/振动: 15g[10Hz~2000Hz]

Shock Resistance/冲击: 100g[6ms]

Endurance (Shell)/机械寿命: 5000次

Cable/配接电缆: $\phi 9.1\text{mm} - \phi 10.0\text{mm}$

2. 电气性能

Insert Configuration/针芯配置: 3T.308 8Low Voltage

Pin Size/接触件直径: $\phi 1.3\text{mm}$

Contact resistance接触电阻: $\leq 5\text{m}\Omega$

Insulation resistance/绝缘电阻: 5000M Ω (测试电压500V(DC))

Withstand voltage/耐电压: 1150V(AC)

Rated working current额定工作电流: 13.0A

Other Specification/其它规格:

Contact PIN/接触体: Gold plated Tin bronze/锡青铜镀金

Housing Material/外壳材质: Chrome plated brass/铜镀珍珠铬

Other metal spare parts/其余金属件: Nickel plated brass/铜镀镍

Insulator material/绝缘材料: PPS

IP Rating/防护等级: IP68(头座插合)

*ALL MATERIALS ARE RoHS COMPLIANT/所有材料均符合RoHS要求.

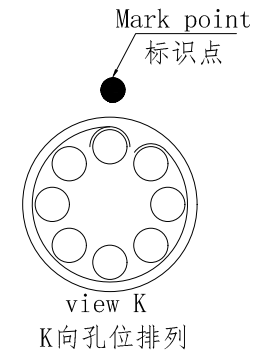
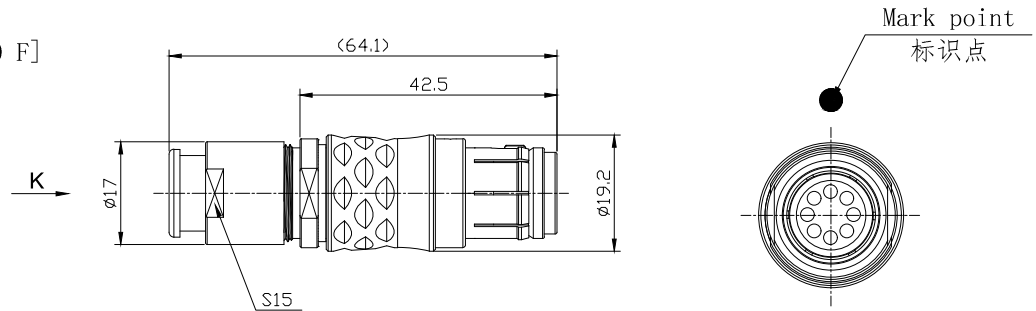

DRAWN BY:
绘图: Z01 2024. 6. 20

CHECKED BY:
审核: Z01 2024. 6. 20

APPROVED BY:
核准: PD05 2024. 6. 20



美易连电子科技(深圳)有限公司
Meiyilian electronic technology (shenzhen) Co. Ltd.

GENERAL TOLERANCE
(UNLESS SPECIFIED)

$\leq 10 \pm 0.1$

$< 10^{\circ} \sim 20^{\circ} \pm 0.15$

$< 20^{\circ} \sim 50^{\circ} \pm 0.3$

Angle $\pm 1^{\circ}$

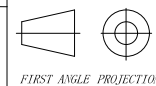

REV/版本

A1

单位
UNITS: mm

比例
SCALE: 1: 1

SIZE: A4

SHEET: 1 OF 1

名称
PART NAME

型号
PART NAME

3T-TG直式插头(带护套式尾帽)
3T-TG Straight plug
(with jacketed tail cap)

TGG. 3T. 308. CLAC102Z